

## Coffee System Multi-boilers espresso machine, white, 2 groups, 2x1.65l boilers for coffee with Dosamat

ITEM # \_\_\_\_\_

MODEL # \_\_\_\_\_

NAME # \_\_\_\_\_

SIS # \_\_\_\_\_

AIA # \_\_\_\_\_



602680 (EPIC2DOW)

Multi-boilers espresso machine white esthetic color, 2 groups, 2 x 1.65 liter boilers for coffee, 8.9 liter hot water & steam boiler, Central control LCD Touch screen, 2 independent control boxes with 4 programmable dosing program with Dosamat ® self recognition of portafilter-Thermalink Network, programmable pre-infusion time per group, Steamglide, programmable steam cool touch & water, automatic cleaning cycle, Easylock portafilter, stainless steel body

### Short Form Specification

Item No. \_\_\_\_\_

The Stella Epic is the flagship for UNIC, with an assertive design inspired from the 50's and a technology fully deep-seated in the digital era, it offers high-end features geared towards the barista keen to explore coffees aromas with high precision.

The Stella Epic is a multi-boiler traditional espresso machine machine that guarantees exceptional brewing with its Thermalink Network® technology and a PID controller for a consistent brewing temperature. Its expert mode gives full control of the settings and allows saving up to 5 recordable extraction profiles per group to enhance high quality coffees extraction. Its brew groups are fitted with the EASYLOCK system that help locking and sealing the portafilter with minimal effort. DOSAMAT ® technology gives also a high level of performance thanks to the autorecognition of the size of portafilter and the automatic dosing execution. Customization and several options exist and complete the Stella Epic standard equipement, so make it Yours! The Stella Epic is the ideal commercial espresso machine for baristas, as well as for coffee shops and businesses offering specialty coffee beverages that call for precise adjustments and maximum steam capacity.

### Main Features

- 8.9 liter hot water & steam boiler
- Easily height-adjustable drip tray to adapt the working area
- White esthetic color body
- 2 x 1.65 liter boilers for coffee
- LED lights on group head
- Programmable water and steam.
- Automatic cleaning cycle.
- Electronic pre infusion.
- Double paneled cup warmer with large capacity.
- USB interface for update.
- Multi-boiler traditional espresso machine with Thermalink Network® technology that intelligently controls and optimizes the distribution of heat, that guarantees consistent brewing temperature and efficiency in terms of energy requirements.
- 2 independent control boxes with 4 programmable dosing selection with Dosamat ® self recognition of portafilter, pre and post infusion profiling manual control, infusion pressure curve and shot time display
- LCD touchscreen to take control of the settings, in expert mode it allows saving up to 5 recordable extraction profiles per group to enhance high quality coffees extraction.
- Cool touch steam outlets to control steam without the risk of burns, easier to clean after each use

### Construction

- PID (proportional-integral-derivative) Temperature control: a precise controller algorithm system that gives consistency and accuracy to brewing temperature management system.
- Manual Steamglide lever.
- Easylock portafilter.
- RS-232 protocol for computer/cashier interface.
- Built-in cup warmer.

APPROVAL: \_\_\_\_\_

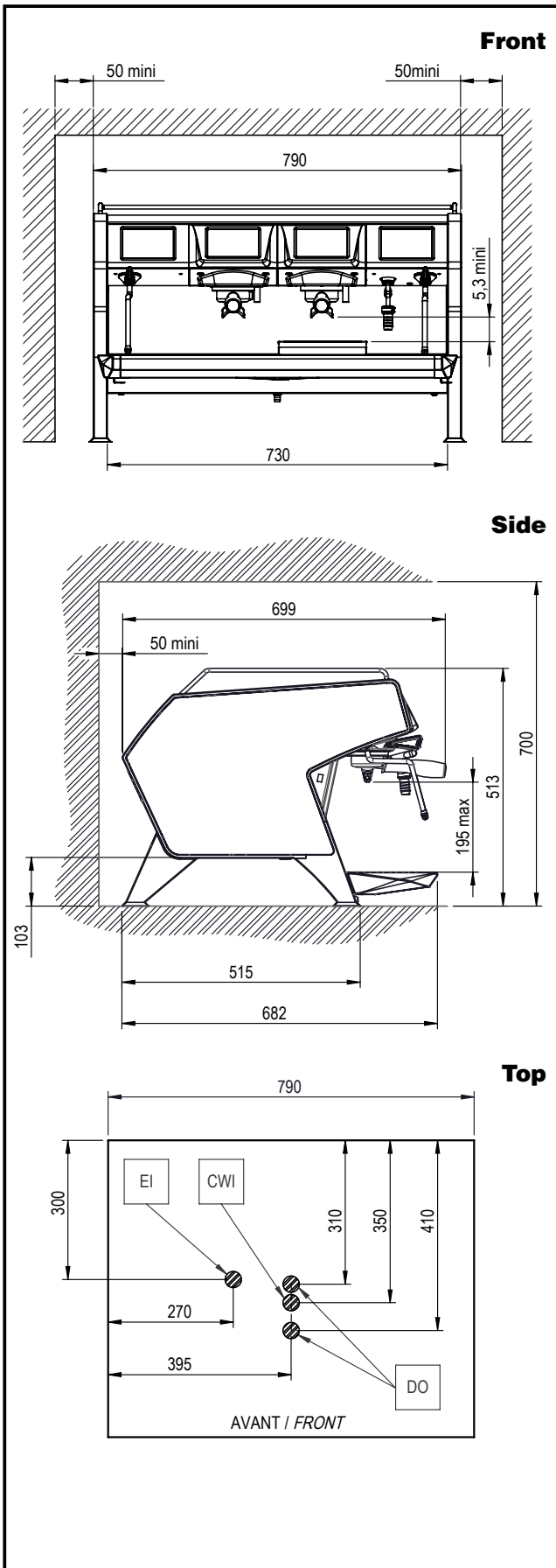

## Electric

Supply voltage:

602680 (EPIC2DOW) 400 V/3N ph/50 Hz

Electrical power max.:

6.7 kW

Current consumption:

Plug type:

Cable without plug

## Water:

Cold water temperature (min/  
max):

5 / 60 °C

## Key Information:

External dimensions, Width: 790 mm

External dimensions, Depth: 682 mm

External dimensions, Height: 513 mm

Net weight: 90 kg

Shipping volume: 0.69 m<sup>3</sup>